

Szczegóły techniczne

BIS Pręty gwintowane: maksymalne zalecane obciążenie

Maksymalne zalecane obciążenie

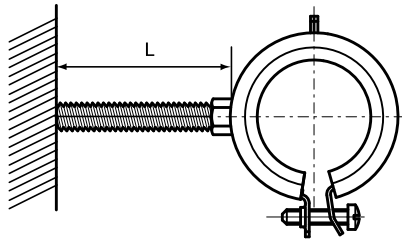

BIS Trzpienie gwintowane / BIS Pręty gwintowane

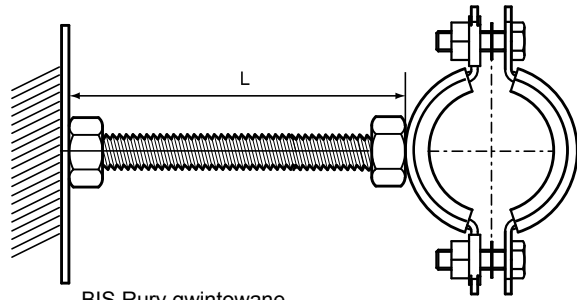

BIS Rury gwintowane

Ø L (mm)	BIS Trzpienie gwintowane / BIS Pręty gwintowane							BIS Rury gwintowane		
	M8	M10	M12	M16	M20	M22	M24	1/2"	3/4"	1"
20	210	422	744	1.936	3.785	5.295	6.542	3.057	5.377	10.693
30	140	281	496	1.291	2.523	3.530	4.361	2.038	3.584	7.128
40	105	211	372	968	1.892	2.647	3.271	1.528	2.688	5.346
50	84	169	297	774	1.514	2.118	2.617	1.223	2.151	4.277
60	70	141	248	645	1.262	1.765	2.181	1.019	1.792	3.564
70	60	120	212	553	1.081	1.513	1.869	873	1.536	3.055
80	50	105	186	484	946	1.324	1.636	764	1.344	2.673
90	40	94	165	430	841	1.177	1.454	679	1.195	2.376
100	32	81	149	387	757	1.059	1.308	611	1.075	2.138
125	21	52	111	310	606	847	1.047	489	860	1.711
150	14	36	77	258	505	706	872	408	717	1.426
175	10	27	57	203	433	605	748	349	614	1.222
200	-	20	43	155	378	529	654	305	538	1.069
225	-	16	34	123	300	469	582	272	478	950
250	-	13	28	99	243	380	504	239	430	855
275	-	11	23	82	201	314	416	198	391	778
300	-	-	19	69	169	264	350	166	358	713
325	-	-	16	59	144	225	298	141	322	658
350	-	-	14	51	124	194	257	122	278	611
375	-	-	12	44	108	169	224	106	242	570
400	-	-	11	39	95	148	197	93	213	231
450	-	-	-	31	75	117	156	74	168	420
500	-	-	-	25	61	95	126	60	136	340

Maksymalne zalecane obciążenie w (N).
Dopuszczalne ugięcie: $f = (1/150) \times L$
Dopuszczalne naprężenia: $\sigma = 160 \text{ N/mm}^2$

W przypadku nietypowych zastosowań proszę skontaktować się z naszym działem technicznym.