

## BISMAT® Flash



*Insert pipe*



*Close clamp / push screw*



*Done!*

### Fixed in a flash, without tools!

- With BISMAT® Flash quick locking system
- Clamp easy to close with one hand without tools
- Tested for fire safety
- RAL-certified

# BISMAT® Flash

The BISMAT® Flash is a single screw pipe clamp with quick locking system. The locking screw can be secured by one simple thumb push. Tools are not required.

The BISMAT® Flash is suitable for fixing of all types of metal pipes Ø 15 mm up to and including 63 mm (3/8" up to and including 2").

The steel locking guarantees safety and reliability in all conditions. The fire resistance properties of BISMAT® Flash are tested by the MaterialPrüfungsAnstalt in Braunschweig (Germany). A copy of the test report is available on request.

## Features and benefits

- Single screw pipe clamp
- With BISMAT® Flash quick locking
- Clamp easy to be closed with one hand
- The locking screw can be secured by one simple thumb push. Tools are not required.
- Material: steel
- Zinc plated
- Noise insulating lining made of EPDM rubber, black
- Tested according to NEN 5077

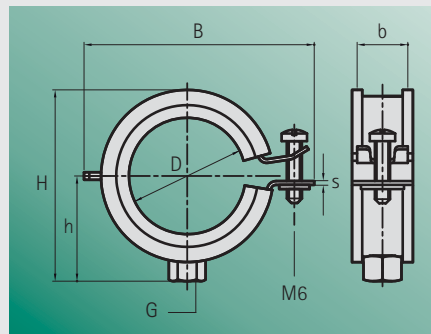

Part No.	G	D			B	H	h	b x s	RAL	Fa,z*	Box (pc.)
		(mm)	(")	(DN)							
337 3 018	M8	15 - 18	3/8	10	49	36	22	20 x 1,00	RAL	500	50
337 3 023	M8	20 - 23	1/2	15	54	39	23	20 x 1,00	RAL	500	50
337 3 028	M8	25 - 28	3/4	20	59	44	26	20 x 1,00	RAL	500	50
337 3 035	M8	32 - 35	1	25	65	51	30	20 x 1,00	RAL	500	50
337 3 043	M8	40 - 43	1 1/4	32	74	60	34	20 x 1,25	RAL	700	50
337 3 051	M8	48 - 51	1 1/2	40	82	66	37	20 x 1,25	RAL	700	50
337 3 056	M8	53 - 56	-	-	85	76	42	20 x 1,25	RAL	700	50
337 3 063	M8	57 - 63	2	50	91	82	45	20 x 1,25	RAL	700	50
337 4 018	M8/10	15 - 18	3/8	10	49	44	30	20 x 1,00	RAL	500	50
337 4 023	M8/10	20 - 23	1/2	15	54	47	31	20 x 1,00	RAL	500	50
337 4 028	M8/10	25 - 28	3/4	20	59	52	34	20 x 1,00	RAL	500	50
337 4 035	M8/10	32 - 35	1	25	65	59	38	20 x 1,00	RAL	500	50
337 4 043	M8/10	40 - 43	1 1/4	32	74	68	42	20 x 1,25	RAL	700	50
337 4 051	M8/10	48 - 51	1 1/2	40	82	74	45	20 x 1,25	RAL	700	50
337 4 056	M8/10	53 - 56	-	-	85	84	50	20 x 1,25	RAL	700	50
337 4 063	M8/10	57 - 63	2	50	91	90	53	20 x 1,25	RAL	700	50

\*The max. allowed load (Fa,z) is calculated using specific statistical methods related to the breaking load and taking into account a deflection of 1,5 mm or 2% of the maximum nominal clamp diameter (respectively according to RAL-GZ 655/B). According to the RAL requirements, the test results from above mentioned RAL certified articles are monitored by an independent test institute.

## RAL

The maximum allowed load is tested and certified according to RAL-GZ 655/B which is drawn up by the 'Gütegemeinschaft Rohrbefestigung'. In the test a maximum allowed deflection is taken into consideration.

The 'RAL-Gütezeichen' is exclusively awarded to products that meet high standards and is a proof of quality!



### Nordic countries

Denmark – Sweden – Finland – Norway – Iceland

#### Walraven B.V.

P.O. Box 15  
3640 AA Mijdrecht (NL)  
salgnorden@walraven.com  
Denmark  
Tel. +45 46 37 05 10  
Fax +45 46 37 05 15  
Sweden  
Tel. +46 (0)40 36 54 20  
Fax +46 (0)40 36 54 15  
Finland, Norway and Iceland  
Tel. +31 (0)297 23 30 17  
+31 (0)297 23 30 04  
Fax +31 (0)297 23 30 99



### United Kingdom

Ireland

#### Walraven Ltd.

Thorpe Way, Banbury (GB)  
Oxon, OX16 4UU  
Tel. +44 (0)1295 75 34 00  
Fax +44 (0)1295 75 34 28  
sales.banbury@walraven.com



### Germany

Austria – Switzerland – South East Europe

#### Walraven GmbH

Postfach 125128  
95425 Bayreuth (DE)  
Tel. +49 (0)921 75 60 0  
Fax +49 (0)921 75 60 111  
info@walraven.de

### Other countries

#### Walraven International

P.O. Box 15  
3640 AA Mijdrecht (NL)  
Tel. +31 (0)297 23 30 00  
Fax +31 (0)297 28 64 09  
export@walraven.com



### Walraven Group

Mijdrecht (NL) · Tienen (BE) · Bayreuth (DE)  
Grenoble (FR) · Banbury (GB) · Madrid (ES)  
Mladá Boleslav (CZ) · Kraków (PL) · Kyiv (UA)  
Moscow (RU) · Rochester Hills (US)

[walraven.com](http://walraven.com)

Your wholesaler: