

Turn down the
volume of buildings

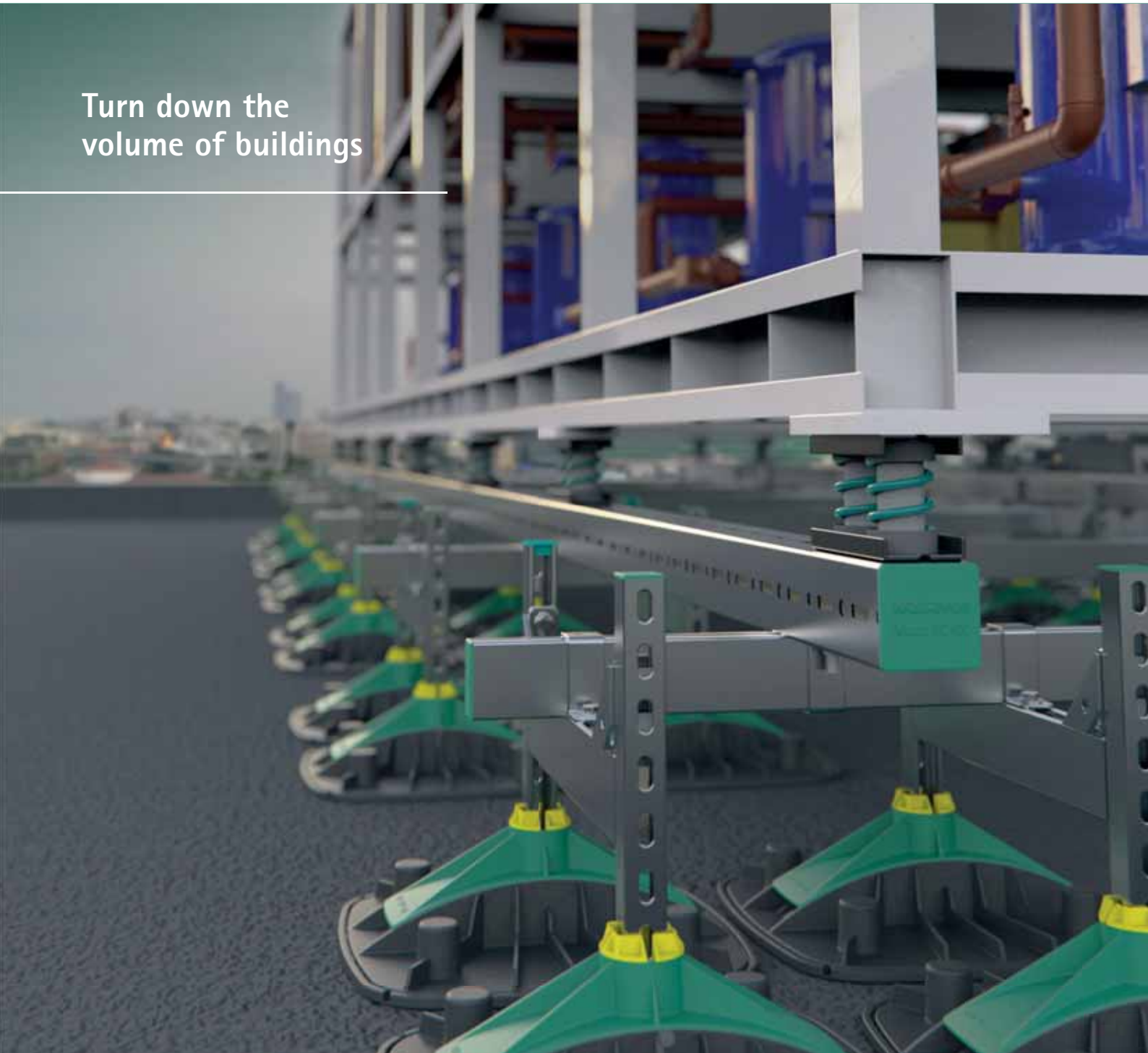

Walraven VibraTek[®]

Vibration isolators for equipment and systems in buildings

Inspired by smart solutions from the start

Walraven was established in 1942. Our founder, the great-grandfather of our current CEO, was an inventor with a love for simple and smart solutions. And now, more than 75 years later, we are a globally active company in the installation industry, committed to develop simple, yet smart product systems. With our wide product range and expert advice, we can provide complete solutions for any project, no matter how large or complex.

Walraven. The value of smart.

Turn down the volume of buildings

As more building users are disturbed by the mechanical vibration and vibration-induced noise originating from mechanical equipment, building owners and facility managers have an increasing awareness of the issue and a desire to prevent vibration.

As a result, the HVAC sector has become more attentive to the acoustic design of mechanical installations. System designers pay more attention to the acoustic performance of the products they specify, while manufacturers stress the importance of correct installation. Onsite, installers aim to prevent noise and vibration from travelling through piping, conduits and ductwork.

Despite the increased focus on anti-vibration measures, building users still often express discomfort resulting from mechanical vibration in buildings.



What is vibration?

In its simplest form, vibration is a mechanical phenomenon where oscillations occur about an equilibrium point. Vibration can be desirable, for example, in the case of a motion of a guitar's string or in the movement of a loudspeaker's membrane. In many cases, however, vibration is undesirable, wasting energy and creating unwanted noise. Typical examples of unwanted vibration include the vibrational motion of engines, or other mechanical devices and equipment in operation.

What are the most common sources of vibration in buildings?

HVAC equipment that is rigidly attached to a slab, wall, or ceiling can transmit vibration into the supporting structure and cause highly undesirable levels of structure-borne noise. This noise can travel far and can be heard throughout the building. Just like equipment, piping, conduits, and ductwork can act as transmitters of structure-borne noise if they are rigidly connected to vibrating equipment.

What are the consequences of vibration?

Unresolved vibration can cause problems affecting both the building and its users. These effects include, for example:

- creating discomfort for people
- safety issues for those near the vibrating equipment
- damage to the structure of the building
- increased maintenance requirements of equipment
- decreased lifetime of equipment
- incorrect operation of equipment
- violation of regulatory requirements

How to resolve vibration?

Isolating the source of vibration from the supporting structure is typically the most efficient approach to eliminate vibration. Carefully selected vibroacoustic isolators need to be placed, where possible, directly in between the mounting structure and the equipment that produces unwanted vibration. The isolators can then effectively absorb up to 99% of excess vibration produced by the equipment.

It is worth noting that correcting a noise or vibration problem in the future can be more difficult and costly than tackling it at the time of installation. The cost of correction can include the time required to coordinate the investigation, direct payments to the retrofitting contractor and possible compensation paid to the building users filing complaints. Therefore, it is always advisable to prevent any vibration issues occurring in the first place. The negligible extra cost for prevention (usually about 1% to 2% of the total HVAC system cost) is money well spent compared to the second-best alternative, which is correcting a problematic situation.

Isolating vibrating equipment from structural building components, such as slabs, walls, and ceilings, is essential for controlling vibration and structure-borne noise transmission. There are many types of isolators available for HVAC equipment, and the most effective selection for each piece of equipment should be considered.

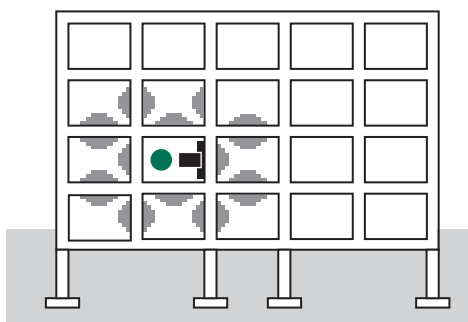

Transmission of airborne noise in a building

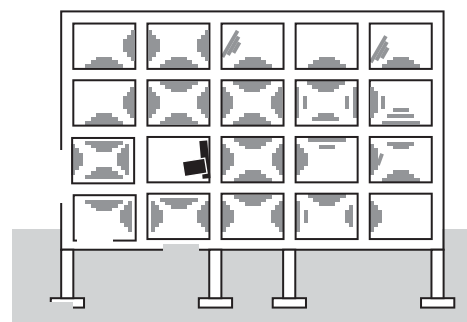

Transmission of structure-borne noise in a building

What information...

is required to select the right isolator?

Below are some of the key factors that influence the selection of the isolator:

■ Equipment specifications

Different types of HVAC equipment will require different solutions. You need to consider the size and weight of the equipment or pipework and its structural attachment points.

■ Location of equipment

The location and support surface of the equipment can affect which types of isolator are required. For example, is it ceiling mounted, floor mounted on a slab in a basement, or is it outdoors on a building rooftop?

■ Vibration excitation of the equipment

The rotational frequency (revolutions per second) of the machinery contribute to the levels of vibration. The forces and couples generated will influence the isolators required to dampen the vibrations.

■ Type of building

Different types of building can have different requirements for vibration and acoustic isolation. For example an entertainment venue, industrial facility or luxury apartment block may have more significant requirements or expectations than some other buildings.

■ Environmental considerations

Whether the equipment is placed indoors or outdoors can make a big difference, but under all circumstances, you need to consider environmental factors such as the degree of corrosivity and the minimum and maximum ambient temperature near the machinery.

■ Special requirements

Last but not least, you need to check if there are any special requirements. For example, are there electrical, pipework or ducting connections that might modify the mechanical response of the mounting system. Are there any externally applied forces or moments; minimum or maximum clearance requirements between equipment and foundation; alignment requirements; or dynamic loads.

Isolated pipelines prevent vibration and noise transmission to the structure of a building



Wide range of isolators

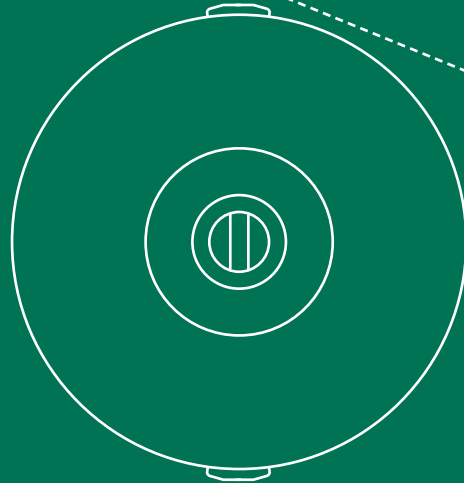

+ High performance



+ Made in EU

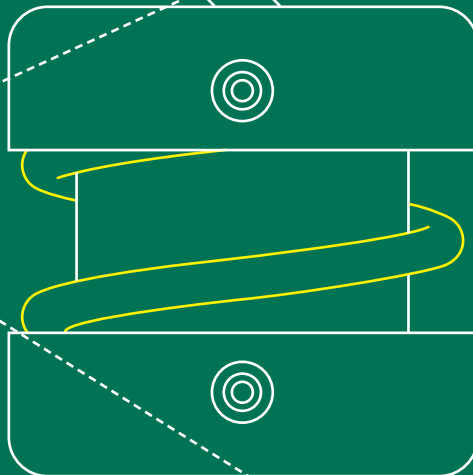

+ Wide range of applications

+ Digital product data & BIM Models

Typical applications

Where can Walraven VibraTek® products be used?

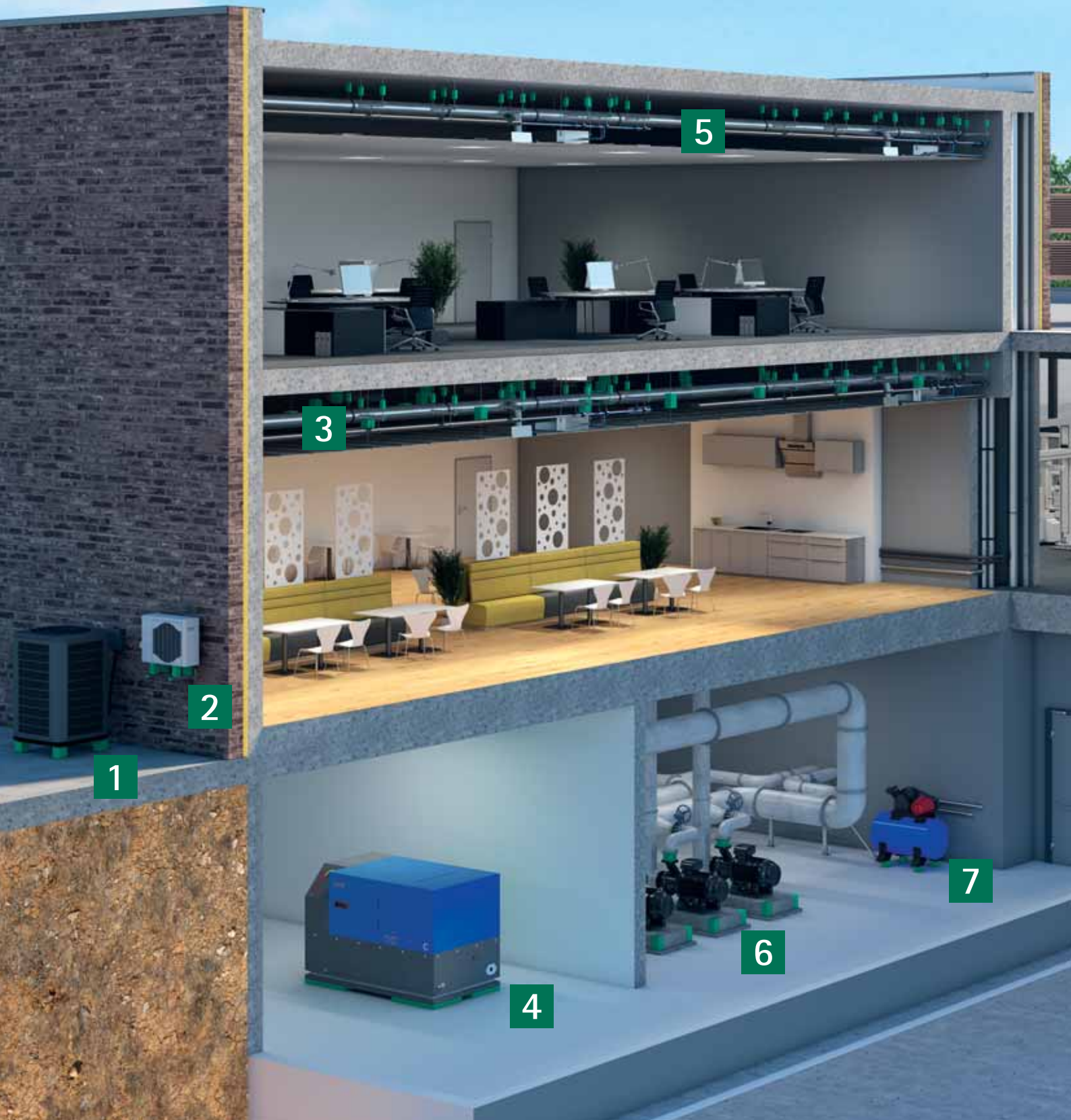



Walraven VibraTek® – Typical applications

- 1 Heat pumps
- 2 Outside AC splits
- 3 Acoustic ceilings
- 4 Backup power generators and cogeneration plants
- 5 Suspended piping systems
- 6 Pumps
- 7 Compressors
- 8 Ventilation ducts
- 9 Rooftop chillers, refrigeration and air handling units
- 10 Inline fans and equipment
- 11 Industrial processing machinery

How to evaluate the suitability of an isolator?

Vibration can be isolated or reduced to a fraction of the original force with isolators placed between the equipment and the supporting structure

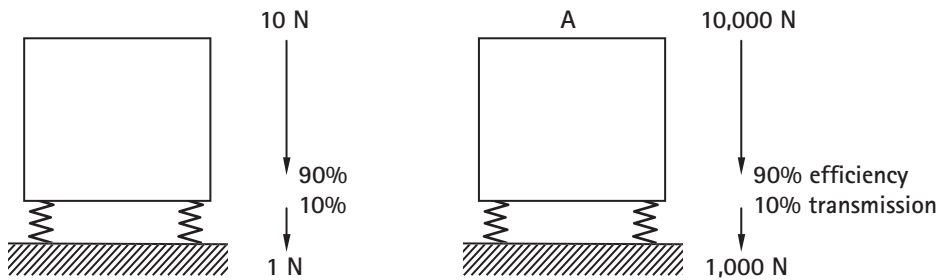

The simplest way to determine vibration transmission to the structure is to use static deflection and vibration isolation efficiency charts available in the Walraven VibraTek® product documentation.

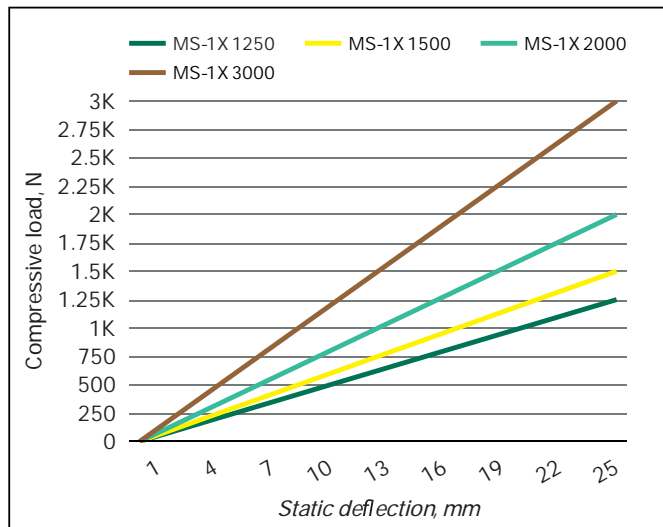

Load-displacement chart

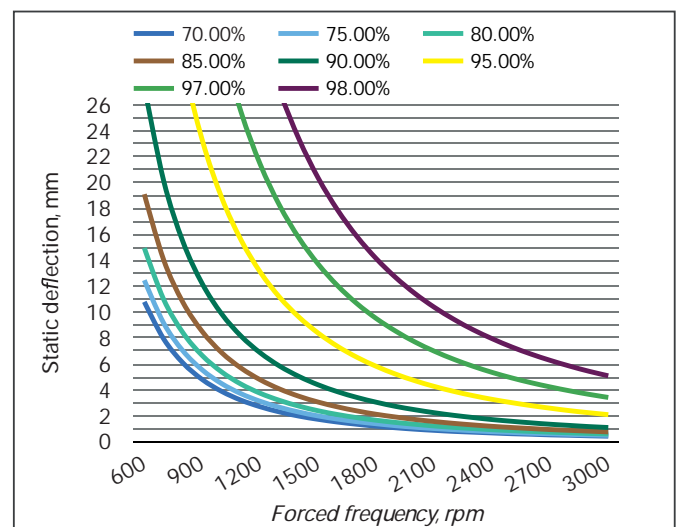

Isolation efficiency chart

First, determine the static deflection of an isolator at a given load. Then, plot the deflection on the isolation efficiency chart to determine the degree of isolation for the given application

The Walraven VibraTek® product range

The Walraven VibraTek® product line consisting of rubber and metal vibroacoustic isolators is a tailor-made solution to eliminate vibration problems in HVAC installations. Our isolators reduce the vibration transmitted by the equipment and ensure the safety and comfort of people and their surrounding environment by reducing harmful noise and vibration to the minimum. In addition, we can combine vibration isolators with Walraven pipe fixings, rail support systems and concrete anchors to provide you with a complete engineered solution from one partner.

MS-M Spring Mount

Compact spring isolator for light equipment



Features and Benefits

- Low-rise spring isolator with M8 external thread for light equipment or tight spaces
- Recommended for machinery with working speeds above 1000 RPM
- Steel frame attached to spring mechanically with metal rivets
- Surface treatment: zinc-plated

Load-displacement charts

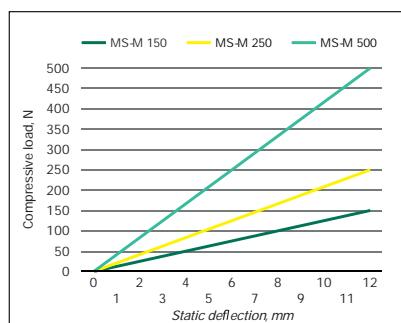

Natural frequency chart

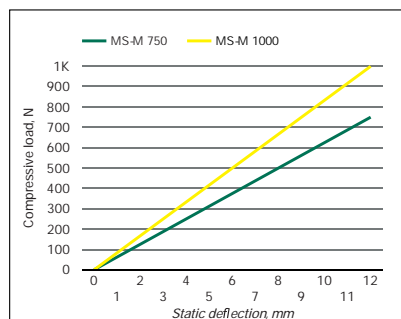
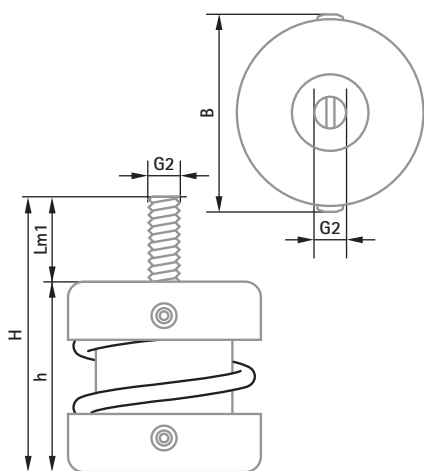
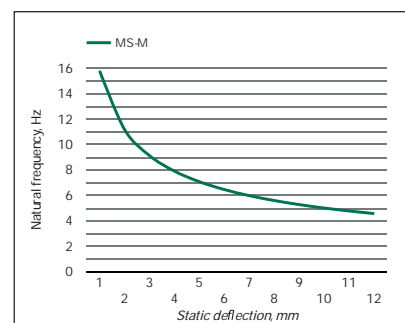

Specifications and Packaging

Part No.	Dimension	Max. Deflection (mm)	Min. load (N)	Max. load (N)	Min. optimal load (N)	Max. optimal load (N)	G1/G2	Lm1	H	h	B
2800200150	150/M8	12mm	25	150	30	140	M8	22.5	73	50.5	Ø51
2800200250	250/M8	12mm	40	250	50	230	M8	22.5	73	50.5	Ø51
2800200500	500/M8	12mm	80	500	100	450	M8	22.5	73	50.5	Ø51
2800200750	750/M8	12mm	125	750	150	680	M8	22.5	73	50.5	Ø51
2800201000	1000/M8	12mm	125	1000	200	980	M8	22.5	73	50.5	Ø51

See Product Data Sheet for further technical information.

Walraven VibraTek®

MS-1 Spring Mount

High performance spring isolator for light equipment



Features and Benefits

- Recommended for equipment with low working speeds, from 700 RPM and above
- Ribs in the metal base provide increased stiffness
- Slot holes facilitate positioning and anchoring to the base material
- Epoxy powder-coated base, caps and springs provide increased resistance to corrosion

Load-displacement charts

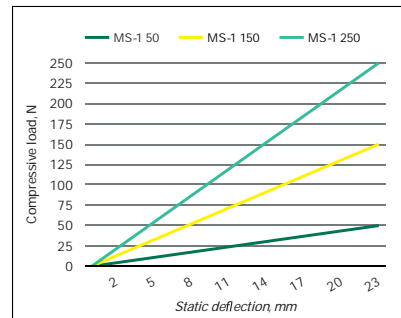

Natural frequency chart

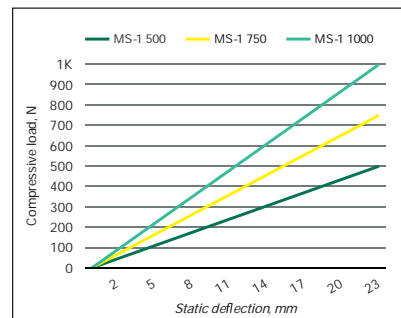
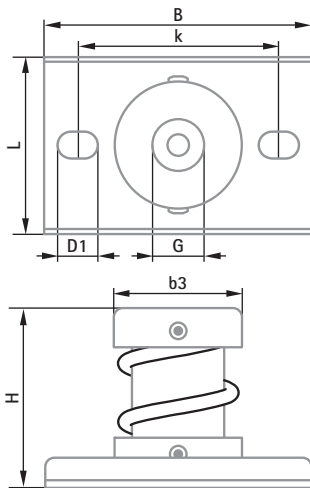
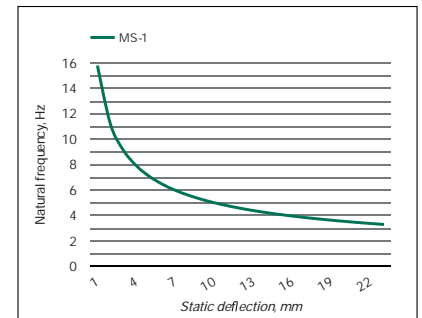

Specifications and Packaging

Part No.	Dimension	Max. Deflection (mm)	Min. load (N)	Max. load (N)	Min. optimal load (N)	Max. optimal load (N)	H	L	B	b3	K	G	d1
2800300050	50/M8	23mm	5	50	10-45	45	71.5	70	106	Ø51	80	M8	16x11
2800300150	150/M8	23mm	20	150	30-140	140	71.5	70	106	Ø51	80	M8	16x11
2800300250	250/M8	23mm	30	250	50-230	230	71.5	70	106	Ø51	80	M8	16x11
2800300500	500/M8	23mm	50	500	100-460	460	71.5	70	106	Ø51	80	M8	16x11
2800300750	750/M8	23mm	80	750	150-690	690	71.5	70	106	Ø51	80	M8	16x11
2800301000	1000/M8	23mm	100	1000	200-920	920	71.5	70	106	Ø51	80	M8	16x11

See Product Data Sheet for further technical information.

MS-1X Spring Mount

High performance spring isolator for medium to heavy equipment



Features and Benefits

- Recommended for equipment with low working speeds, from 600 RPM and above
- Flexible internal filler prevents debris and solid elements entering and damaging the spring under load
- Ribs in the metal base provide increased stiffness
- Slot holes facilitate positioning and anchoring to the base material
- Epoxy powder-coated base, caps and springs provide increased resistance to corrosion

Load-displacement charts

Natural frequency chart

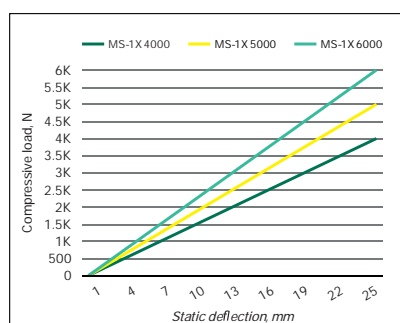
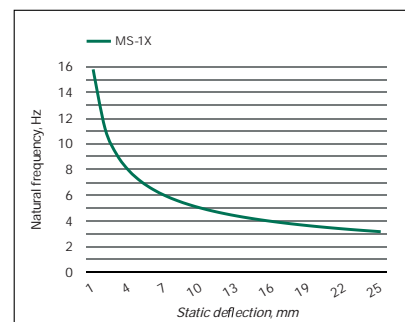
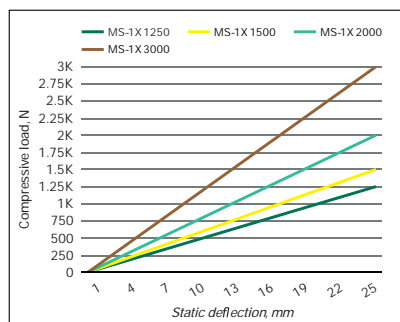
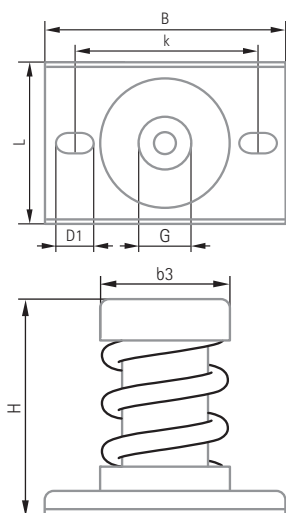

Specifications and Packaging

Part No.	Dimension	Max. Deflection (mm)	Min. load (N)	Max. load (N)	Min. optimal load (N)	Max. optimal load (N)	B	K	L	d1	G	b3	H
2800401250	1250/M12	25mm	130	1250	250	1150	128	96	86	20x11	M12	69	116
2800401500	1500/M12	25mm	150	1500	300	1380	128	96	86	20x11	M12	69	116
2800402000	2000/M12	25mm	200	2000	400	1840	128	96	86	20x11	M12	69	116
2800403000	3000/M12	25mm	300	3000	600	2760	128	96	86	20x11	M12	69	116
2800404000	4000/M12	25mm	400	4000	800	3680	128	96	86	20x11	M12	69	116
2800405000	5000/M12	25mm	500	5000	1000	4600	128	96	86	20x11	M12	69	116
2800406000	6000/M12	25mm	600	6000	1200	5520	128	96	86	20x11	M12	69	116

See Product Data Sheet for further technical information.

Walraven VibraTek®

MS-1X-CBL Spring Mount

High performance spring isolator for use with A-L1 welding bracket and concrete inertia base frames



Features and Benefits

- Recommended for machinery with low working speeds above 600 RPM
- Flexible internal filler prevents debris and solid elements entering and damaging the spring under load
- Ribs in the metal base provide increased stiffness
- Slot holes facilitate positioning and anchoring to the base material
- Epoxy powder-coated base, caps and springs provide increased resistance to corrosion

Load-displacement charts

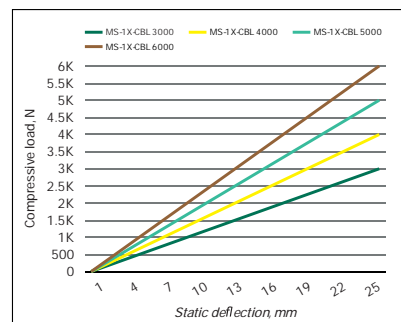
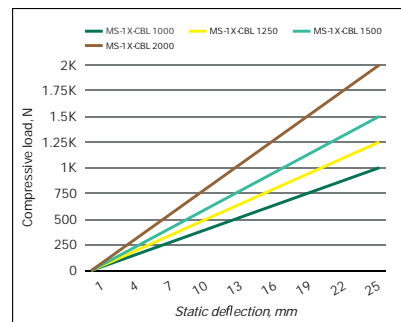

Natural frequency chart

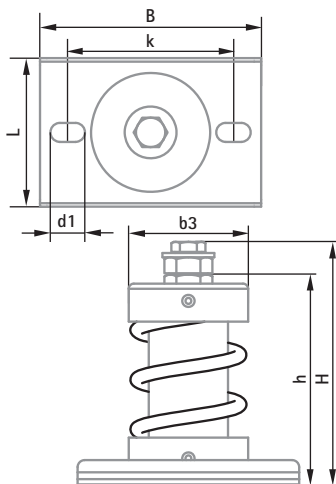
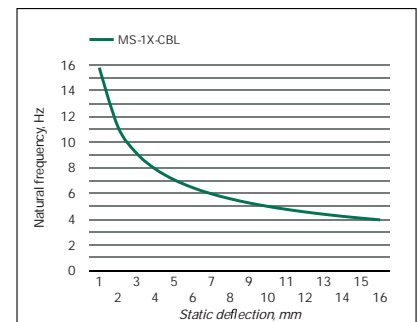

Specifications and Packaging

Part No.	Dimension	Max. Deflection (mm)	Min. load (N)	Max. load (N)	Min. optimal load (N)	Max. optimal load (N)	L	B	H	h	k	d1	b3
2801901000	1000/M10	25mm	100	1000	200	920	86	128	140.1	121.2	96	20x11	Ø69
2801901250	1250/M10	25mm	130	1250	250	1150	86	128	140.1	121.2	96	20x11	Ø69
2801901500	1500/M10	25mm	150	1500	300	1380	86	128	140.1	121.2	96	20x11	Ø69
2801902000	2000/M10	25mm	200	2000	400	1840	86	128	140.1	121.2	96	20x11	Ø69
2801903000	3000/M10	25mm	300	3000	600	2760	86	128	140.1	121.2	96	20x11	Ø69
2801904000	4000/M10	25mm	400	4000	800	3680	86	128	140.1	121.2	96	20x11	Ø69
2801905000	5000/M10	25mm	500	5000	1000	4600	86	128	140.1	121.2	96	20x11	Ø69
2801906000	6000/M10	25mm	600	6000	1200	5520	86	128	140.1	121.2	96	20x11	Ø69

See Product Data Sheet for further technical information.

A-L1 Angle Bracket for Welding

An L-shaped welding bracket



Features and Benefits

- For welding to concrete inertia base frames and use in combination with MS-1X-CBL spring isolators
- Welding provides flexibility in application design
- Epoxy-powder coated for corrosion resistance

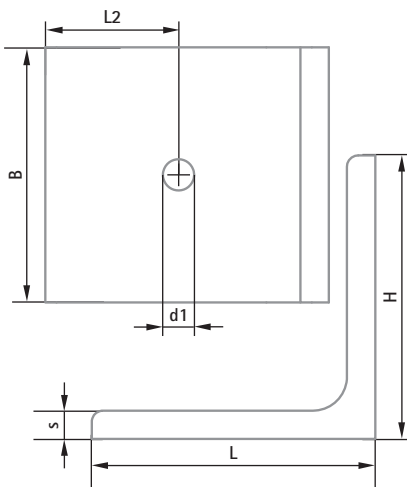

Specifications and Packaging

Part No.	Dimension	L	B	H	s	d1	L2
2802100100	100x100x90	100	90	100	10	Ø11	47

See Product Data Sheet for further technical information.

Walraven VibraTek®

MS-2X Spring Mount

High performance spring isolator for heavy equipment

Features and Benefits



- Recommended for equipment with low working speeds, from 600 RPM and above
- Flexible internal filler prevents debris and solid elements entering and damaging the spring under load
- Ribs in the metal base provide increased stiffness
- Slot holes facilitate positioning and anchoring to the base material
- Epoxy powder-coated base, caps and springs provide increased resistance to corrosion

Load-displacement charts

Natural frequency chart

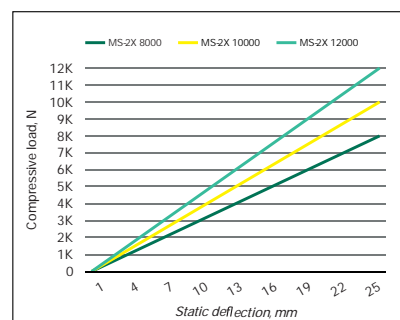
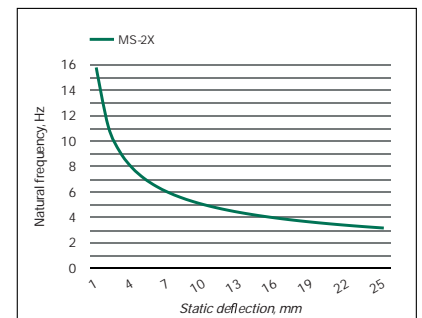
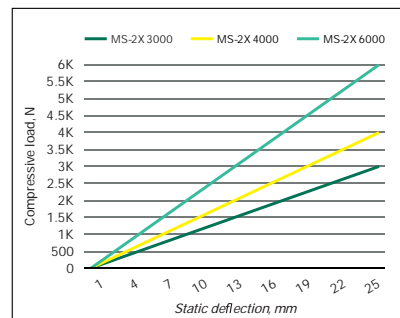
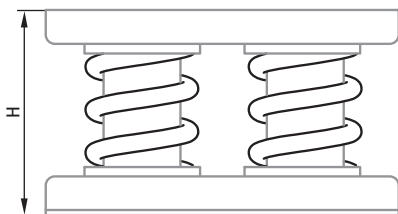
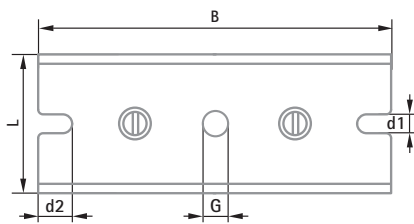

Specifications and Packaging

Part No.	Dimension	Max. Deflection (mm)	Min. load (N)	Max. load (N)	Min. optimal load (N)	Max. optimal load (N)	H	L	B	G	d1	d2
2802003000	3000/M12	25mm	300	3000	600	2760	122	83	210	M12	11	20
2802004000	4000/M12	25mm	400	4000	800	3680	122	83	210	M12	11	20
2802006000	6000/M12	25mm	600	6000	1200	5520	122	83	210	M12	11	20
2802008000	8000/M12	25mm	800	8000	1600	7360	122	83	210	M12	11	20
2802010000	10000/M12	25mm	1000	10000	2000	9200	122	83	210	M12	11	20
2802012000	12000/M12	25mm	1200	12000	2400	11040	122	83	210	M12	11	20

See Product Data Sheet for further technical information.

MS-4 Spring Mount

High performance spring isolator for medium to heavy equipment



Features and Benefits

- Recommended for equipment with low working speeds, from 600 RPM and above
- Flexible internal filler prevents debris and solid elements entering and damaging the spring under load
- Ribs in the metal base provide increased stiffness
- Slot holes facilitate positioning and anchoring to the base material
- Epoxy powder-coated base, caps and springs provide increased resistance to corrosion

Load-displacement charts

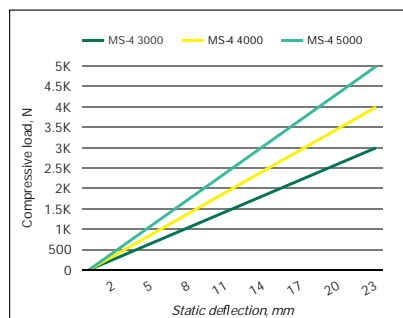
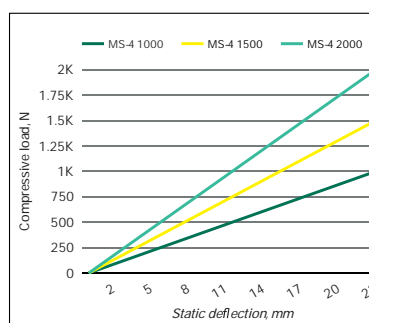

Natural frequency chart

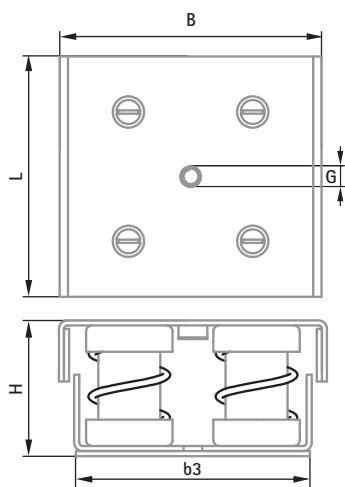
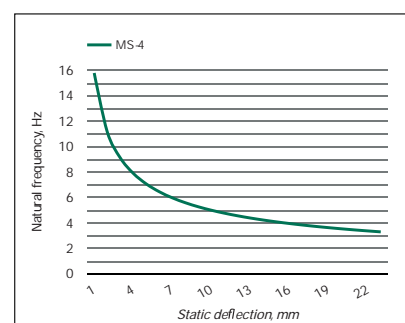

Specifications and Packaging

Part No.	Dimension	Max. Deflection (mm)	Min. load (N)	Max. load (N)	Min. optimal load (N)	Max. optimal load (N)	H	L	B	b3	G
2800501000	1000/M10	23mm	100	1000	200	900	80	145	158	140	M10
2800501500	1500/M10	23mm	130	1500	260	1350	80	145	158	140	M10
2800502000	2000/M10	23mm	200	2000	400	1800	80	145	158	140	M10
2800503000	3000/M10	23mm	300	3000	700	2700	80	145	158	140	M10
2800504000	4000/M10	23mm	400	4000	800	3600	80	145	158	140	M10
2800505000	5000/M10	23mm	500	5000	1000	4500	80	145	158	140	M10

See Product Data Sheet for further technical information.

Walraven VibraTek®

MR-B Rubber Mount

Bell-shaped elastomer isolator for isolation of equipment and machinery



Features and Benefits

- Ideally suited for machinery with radial vibration (as opposed to axial) and prone to sudden or pronounced starts and stops
- Recommended for machinery with working speeds above 2500 RPM, providing a degree of vibration insulation from 75% to 80%
- Metal and rubber parts can be separated for recycling

Load-displacement charts

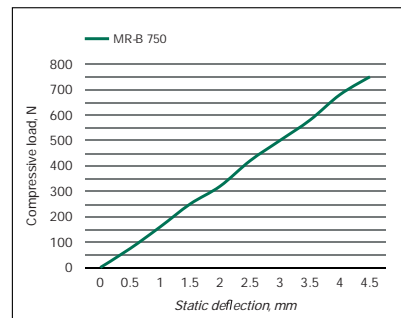
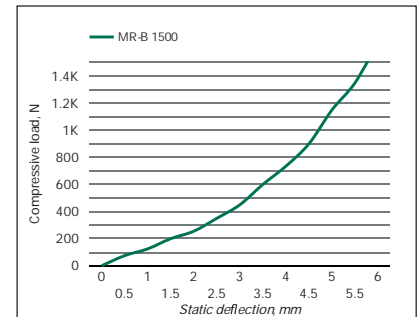
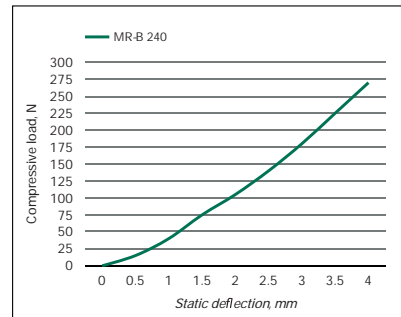
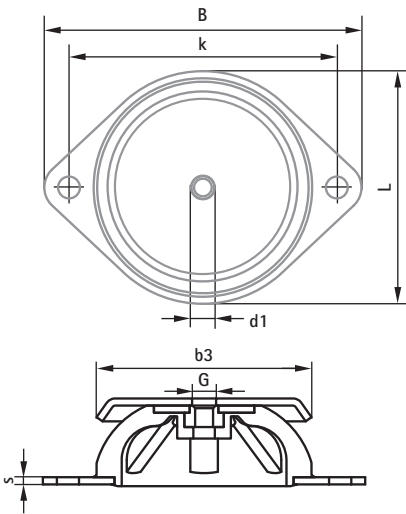

Specifications and Packaging

Part No.	Dimension	Max. Deflection (mm)	Min. load (N)	Max. load (N)	Min. optimal load (N)	Max. optimal load (N)	B	L	K	d1	d2	b3	G	H	s
2801800240	240/M6	3.5	25	240	50	225	90	66	76	6.7	6.2	60	M6	24	2
2801800750	750/M8	4	50	750	130	700	120	86	100	8.2	8.2	80	M8	27	3
2801801500	1500/M10	5.5	100	1500	150	1400	148	106	124	11	10.2	100	M10	28	3

See Product Data Sheet for further technical information.

MR-L Levelling Mount

Rubber mount with M8 connection for equipment isolation and levelling



Features and Benefits

- Rubber isolator with DIN 934 nuts and DIN 9012 washers included in delivery for mounting and levelling equipment
- Simple to install and does not need to be fixed to the supporting structure
- Recommended for machinery with working speeds above 2500 RPM, providing a degree of vibration insulation from 75% to 80%
- Metal and rubber parts can be separated for recycling

Load-displacement charts

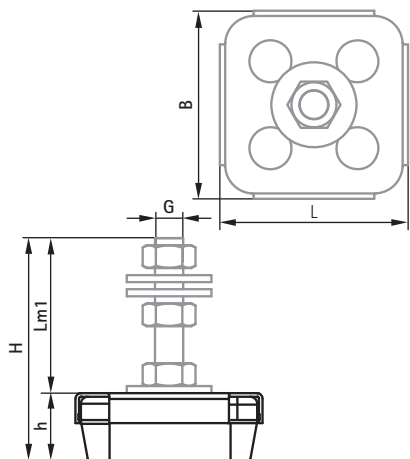
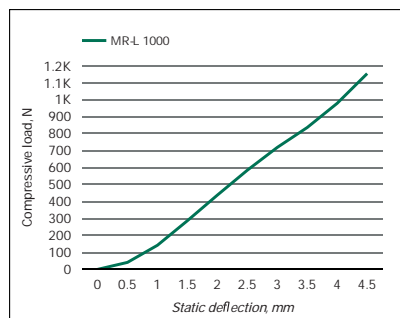

Specifications and Packaging

Part No.	Dimension	Max. Deflection (mm)	Min. load (N)	Max. load (N)	Min. optimal load (N)	Max. optimal load (N)	B	L	G	Lm1	H	h
2800101000	1000/M8	4mm	50	1000	1000	800	53	53	M8	44	63	19

See Product Data Sheet for further technical information.

Walraven VibraTek®

MR-L Levelling Mount

Rubber mount with M10 connection for equipment isolation and levelling



Features and Benefits

- Rubber isolator with DIN 934 nuts and DIN 9012 washers included in delivery for mounting and levelling equipment
- Simple to install and does not need to be fixed to the supporting structure
- Recommended for machinery with working speeds above 2500 RPM, providing a degree of vibration insulation from 75% to 80%
- Metal and rubber parts can be separated for recycling

Load-displacement charts

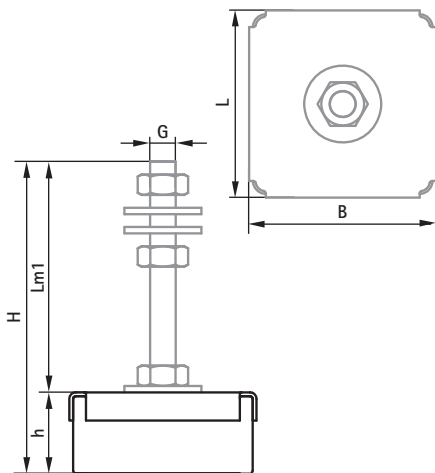
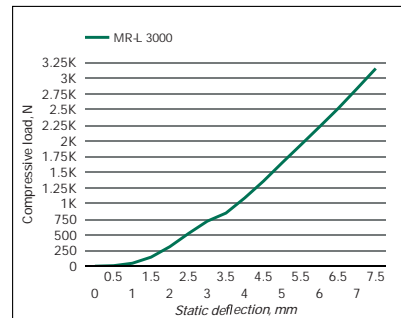

Specifications and Packaging

Part No.	Dimension	Max. Deflection (mm)	Min. load (N)	Max. load (N)	Min. optimal load (N)	Max. optimal load (N)	B	L	G	Lm1	H	h
2800103000	3000/M10	7.5mm	20	3000	100	2500	73	73	M10	90	121.5	31.5

See Product Data Sheet for further technical information.

MR-L Levelling Mount

Rubber mount with M12 connection for equipment isolation and levelling



Features and Benefits

- Rubber isolator with DIN 934 nuts and DIN 9012 washers included in delivery for mounting and levelling equipment
- Simple to install and does not need to be fixed to the supporting structure
- Recommended for machinery with working speeds above 2500 RPM, providing a degree of vibration insulation from 75% to 80%
- Metal and rubber parts can be separated for recycling

Load-displacement charts

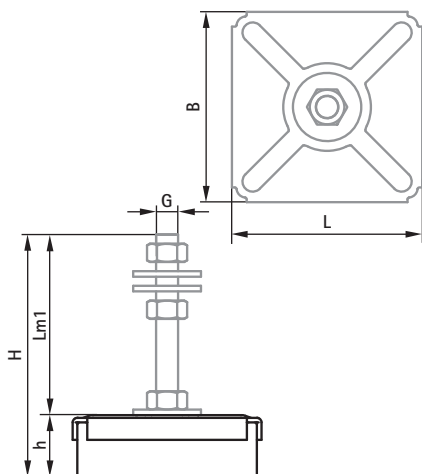
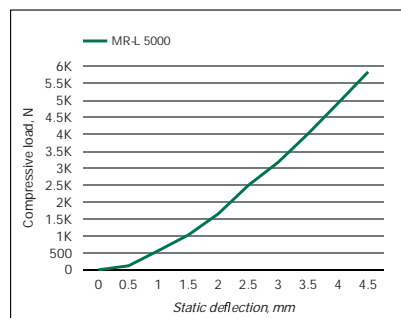

Specifications and Packaging

Part No.	Dimension	Max. Deflection (mm)	Min. load (N)	Max. load (N)	Min. optimal load (N)	Max. optimal load (N)	B	L	G	Lm1	H	h
2800105000	5000/M20	4.5mm	125	5000	700	4500	103	103	M12	100	132	32

See Product Data Sheet for further technical information.

Walraven VibraTek®

MR-L Levelling Mount

Rubber mount with M16 connection for equipment isolation and levelling



Features and Benefits

- Rubber isolator with DIN 934 nuts and DIN 9012 washers included in delivery for mounting and levelling equipment
- Simple to install and does not need to be fixed to the supporting structure
- Recommended for machinery with working speeds above 2500 RPM, providing a degree of vibration insulation from 75% to 80%
- Metal and rubber parts can be separated for recycling

Load-displacement charts

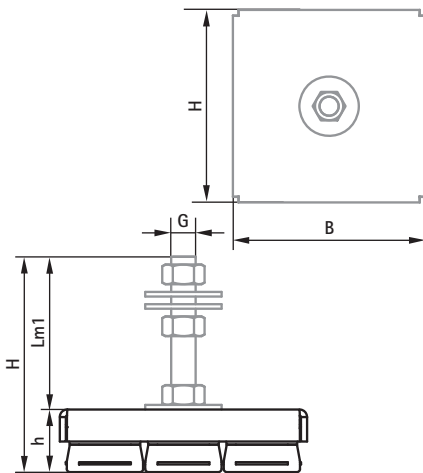
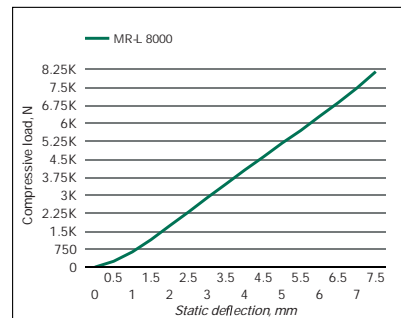

Specifications and Packaging

Part No.	Dimension	Max. Deflection (mm)	Min. load (N)	Max. load (N)	Min. optimal load (N)	Max. optimal load (N)	B	L	G	Lm1	H	h
2800108000	8000/M16	7.5mm	500	8000	1000	7500	162	162	M16	100	141	41

See Product Data Sheet for further technical information.

HS-1 Spring Hanger

High performance spring isolator for light suspended loads

Features and Benefits



- Simple to install and does not need to be fixed to the base material
- Recommended for machinery with low working speeds above 700 RPM
- Rubber spring base cup prevents contact between housing and the spring
- Epoxy powder-coated housing, cap and spring provide increased resistance to corrosion

Load-displacement charts

Natural frequency chart

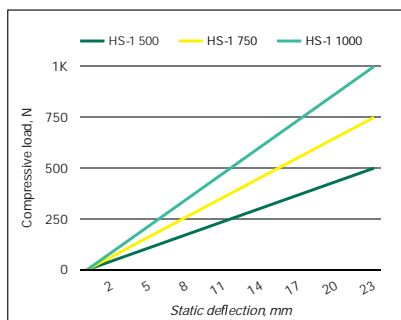
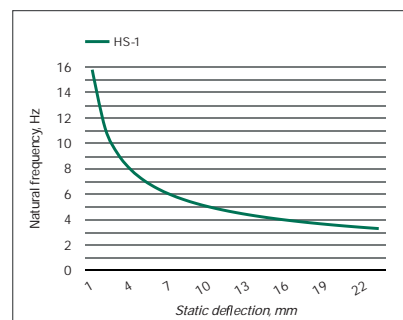
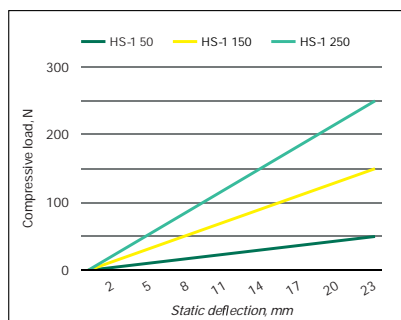
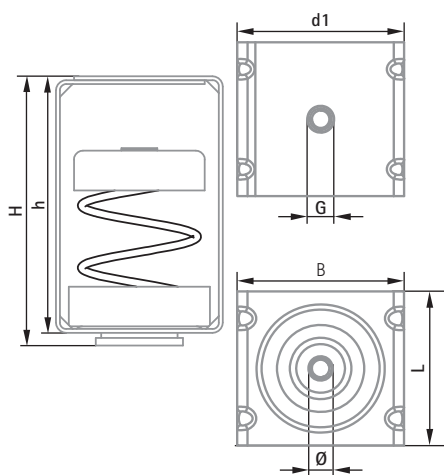

Specifications and Packaging

Part No.	Dimension	Max. Deflection (mm)	Min. load (N)	Max. load (N)	Min. optimal load (N)	Max. optimal load (N)	d1	G	H	h	B	L	Ø
2800600050	50/M8	23mm	5	50	10	45	Ø 10,5	M8	105	100	65	60	24
2800600150	150/M8	23mm	20	150	30	140	Ø 10,5	M8	105	100	65	60	24
2800600250	250/M8	23mm	30	250	50	230	Ø 10,5	M8	105	100	65	60	24
2800600500	500/M8	23mm	50	500	100	450	Ø 10,5	M8	105	100	65	60	24
2800600750	750/M8	23mm	80	750	150	690	Ø 10,5	M8	105	100	65	60	24
2800601000	1000/M8	23mm	100	1000	200	920	Ø 10,5	M8	105	100	65	60	24

See Product Data Sheet for further technical information.

Walraven VibraTek®

HS-1X Spring Hanger

High performance spring isolator for medium to heavy suspended loads



Features and Benefits

- Simple to install and does not need to be fixed to the base material
- Recommended for machinery with low working speeds above 700 RPM
- Rubber spring base cup prevents contact between housing and the spring
- Epoxy powder-coated housing, cap and spring provide increased resistance to corrosion

Load-displacement charts

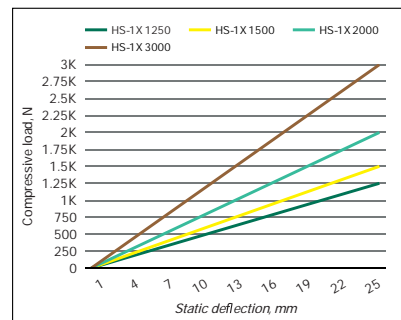

Natural frequency chart

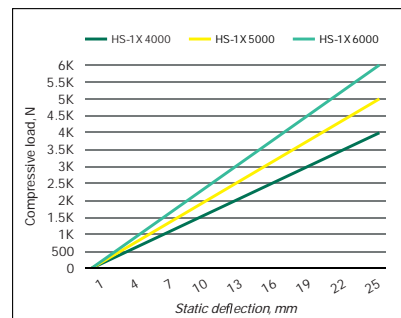
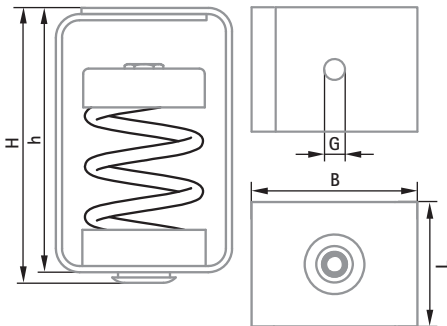
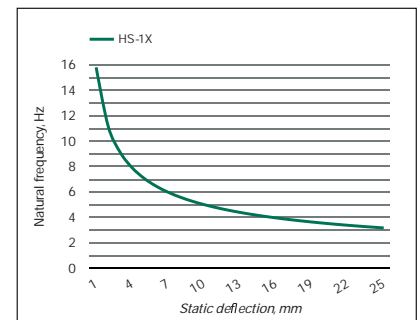

Specifications and Packaging

Part No.	Dimension	Max. Deflection (mm)	Min. load (N)	Max. load (N)	Min. optimal load (N)	Max. optimal load (N)	L	B	H	h	G	Ø
2800701000	1000/M12	25mm	100	1000	200	900	75	100	156	150	M12	22
2800701250	1250/M12	25mm	130	1250	250	1150	75	100	156	150	M12	22
2800701500	1500/M12	25mm	150	1500	300	1380	75	100	156	150	M12	22
2800702000	2000/M12	25mm	200	2000	400	1840	75	100	156	150	M12	22
2800703000	3000/M12	25mm	300	3000	600	2760	75	100	156	150	M12	22
2800704000	4000/M12	25mm	400	4000	800	3680	75	100	156	150	M12	22
2800705000	5000/M12	25mm	500	5000	1000	4600	75	100	156	150	M12	22
2800706000	6000/M12	25mm	600	6000	1200	5400	75	100	156	150	M12	22

See Product Data Sheet for further technical information.

HR-1 Rubber Hanger

Rubber hanger for isolation of suspended ventilation and AC systems

Features and Benefits



- Small footprint allows placement in compact spaces
- Simple to install and adaptable to a sloping roof or ceiling, part of the metal housing swivels

Load-displacement charts

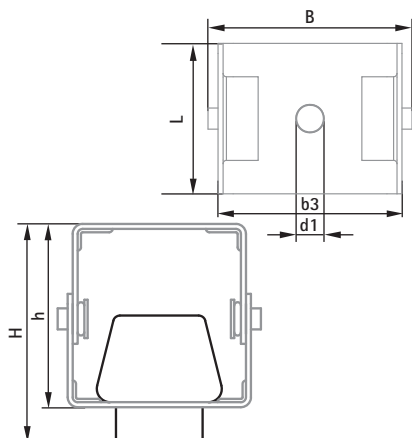

Specifications and Packaging

Part No.	Dimension	Max. Deflection (mm)	Min. load (N)	Max. load (N)	Min. optimal load (N)	Max. optimal load (N)	B	d1	L	b3	H	h	Ø
2800800300	300	7.0mm	5	300	5	250	61	Ø 8,5	45	55	65,5	55	Ø8
2800800450	450	7.0mm	10	450	10	400	61	Ø 8,5	45	55	65,5	55	Ø8

See Product Data Sheet for further technical information.

Walraven VibraTek®

SA-1 Silent Absorber

Silent rubber absorber for isolating metal to metal contact

Features and Benefits



- A versatile viscoelastic rubber absorber for preventing metal-to-metal contact in joined or fastened surfaces
- Prevents transmission of vibration and noise
- With $\varnothing 8\text{mm}$ hole for use with M8 threaded rods
- Simple installation

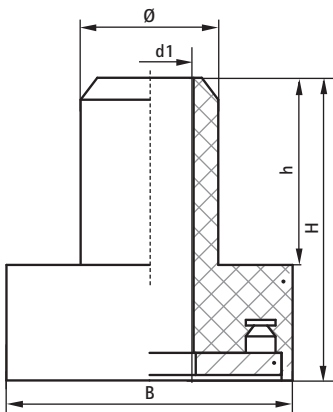

Specifications and Packaging

Part No.	Dimension	Max. Deflection (mm)	Min. load (N)	Max. load (N)	Min. optimal load (N)	Max. optimal load (N)	H	h	B	d1	Ø
2800900300	300	3	5	300	10	180	27.5	17	Ø26	Ø8	Ø12.5

See Product Data Sheet for further technical information.

SA-2 Silent Absorber

Silent rubber absorber for isolating metal to metal contact

Features and Benefits



- A versatile viscoelastic rubber absorber for preventing metal-to-metal contact in joined or fastened surfaces
- Prevents transmission of vibration and noise
- With $\varnothing 8\text{mm}$ hole for use with M8 threaded rods
- Simple installation

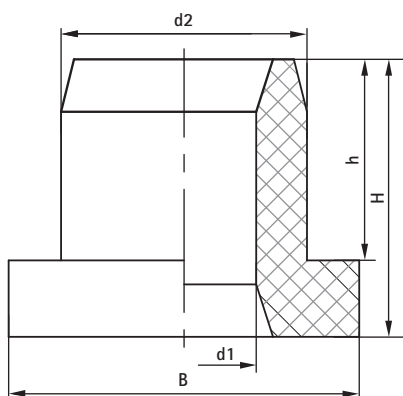

Specifications and Packaging

Part No.	Dimension	Max. Deflection (mm)	Min. load (N)	Max. load (N)	Min. optimal load (N)	Max. optimal load (N)	d1	d2	B	H	h
2801000300	300	3	10	300	10	250	$\varnothing 13.8$	$\varnothing 23.5$	$\varnothing 33.5$	26.5	19.2

See Product Data Sheet for further technical information.

Walraven VibraTek®

SA-3 Silent Absorber

Silent rubber absorber for isolating metal to metal contact

Features and Benefits

- A versatile viscoelastic two-piece rubber absorber for preventing metal-to-metal contact in joined or fastened surfaces
- Formed of two rubber parts which fit into each other, making it suitable for various fixing plate thicknesses
- Prevents transmission of vibration and noise
- Ideal isolation of HVAC equipment
- For use with M8 threaded rods
- Simple installation

Load-displacement chart

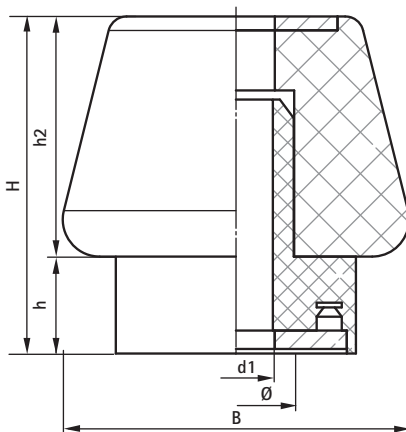
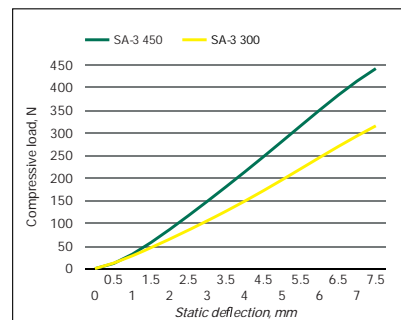

Specifications and Packaging

Part No.	Dimension	Colour	Max. Deflection (mm)	Min. load (N)	Max. load (N)	Min. optimal load (N)	Max. optimal load (N)	H	h	h2	B	d1	Ø
2801100300	300	Grey	7	5	300	5	20	36.5	10.5	26	37.5	Ø8	12.5
2801100450	450	Black	7	10	450	10	400	36.5	10.5	26	37.5	Ø8	12.5

See Product Data Sheet for further technical information.

SB-MM Silentblock

A rubber silentblock with two external threads

Features and Benefits



- A universal rubber absorber, ideal for use with all kinds of elastic suspension or mounting of equipment
- Ideal for use with machinery and equipment mounted on metallic surface
- Available in five configurations: (1) SB-MM with two external threads, (2) SB-MF with one external and one internal thread, (3) SB-FF with two internal threads, (4) SB-M with one external thread and a rubber base, and (5) SB-F with one internal thread and a rubber base
- For use in compression only

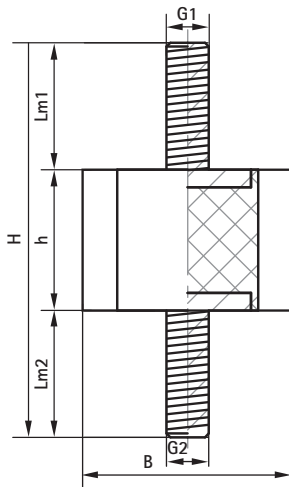

Specifications and Packaging

Part No.	Dimension	Max. Deflection (mm)	Max. load (N)	H	h	Lm1	Lm2	G1	G2	B
2801400180	180/M6	2.0	180	56	20	18	18	M6	M6	20
2801400290	290/M6	2.0	290	56	20	18	18	M6	M6	25
2801400420	420/M8	2.5	420	71	25	23	23	M8	M8	30
2801400750	750/M8	4.0	750	86	40	23	23	M8	M8	40
2801401170	1170/M10	4.0	1170	96	40	27	27	M10	M10	50
2801401690	1690/M12	4.0	1690	114	40	37	37	M12	M12	60

See Product Data Sheet for further technical information.

Walraven VibraTek®

SB-MF Silentblock

A rubber silentblock with an external and internal thread

Features and Benefits



- A universal rubber absorber, ideal for use with all kinds of elastic suspension or mounting of equipment
- Ideal for use with machinery and equipment mounted on metallic surface
- Available in five configurations: (1) SB-MM with two external threads, (2) SB-MF with one external and one internal thread, (3) SB-FF with two internal threads, (4) SB-M with one external thread and a rubber base, and (5) SB-F with one internal thread and a rubber base
- For use in compression only

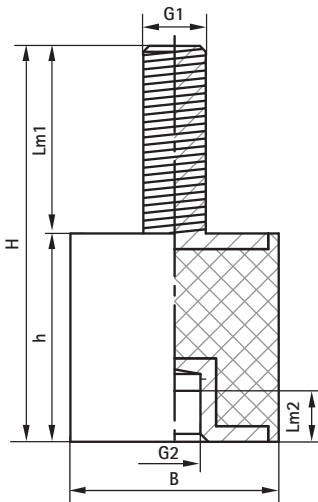

Specifications and Packaging

Part No.	Dimension	Max. Deflection (mm)	Max. load (N)	H	h	Lm1	Lm2	G1	G2	B
2801500180	180/M6	2.0	180	38	20	18	6	M6	M6	20
2801500290	290/M6	2.0	290	38	20	18	6	M6	M6	25
2801500420	420/M8	2.5	420	48	25	23	7	M8	M8	30
2801500750	750/M8	4.0	750	63	40	23	7	M8	M8	40
2801501170	1170/M10	4.0	1170	68	40	27	7	M10	M10	50
2801501690	1690/M12	4.0	1690	77	40	37	10	M12	M12	60

See Product Data Sheet for further technical information.

SB-FF Silentblock

A rubber silentblock with two internal threads



Features and Benefits

- A universal rubber absorber, ideal for use with all kinds of elastic suspension or mounting of equipment
- Ideal for use with machinery and equipment mounted on metallic surface
- Available in five configurations: (1) SB-MM with two external threads, (2) SB-MF with one external and one internal thread, (3) SB-FF with two internal threads, (4) SB-M with one external thread and a rubber base, and (5) SB-F with one internal thread and a rubber base
- For use in compression only

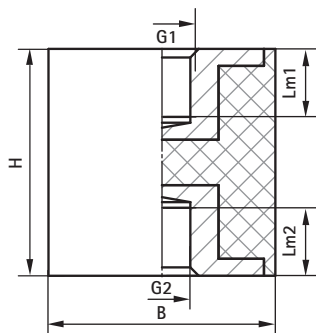

Specifications and Packaging

Part No.	Dimension	Max. Deflection (mm)	Max. load (N)	H	B	G1	G2	Lm1	Lm2
2801600180	180/M6	2.0	180	20	20	M6	M6	6	6
2801600290	290/M6	2.0	290	20	25	M6	M6	6	6
2801600420	420/M8	2.5	420	25	30	M8	M8	7	7
2801600750	750/M8	4.0	750	40	40	M8	M8	7	7
2801601170	1170/M10	4.0	1170	40	50	M10	M10	7	7
2801601690	1690/M12	4.0	1690	40	60	M12	M12	10	10

See Product Data Sheet for further technical information.

Walraven VibraTek®

SB-M Silentblock

A rubber silentblock with one external thread



Features and Benefits

- A universal rubber absorber, ideal for use with all kinds of elastic suspension or mounting of equipment
- Ideal for use with machinery and equipment mounted on metallic surface
- Available in five configurations: (1) SB-MM with two external threads, (2) SB-MF with one external and one internal thread, (3) SB-FF with two internal threads, (4) SB-M with one external thread and a rubber base, and (5) SB-F with one internal thread and a rubber base
- For use in compression only

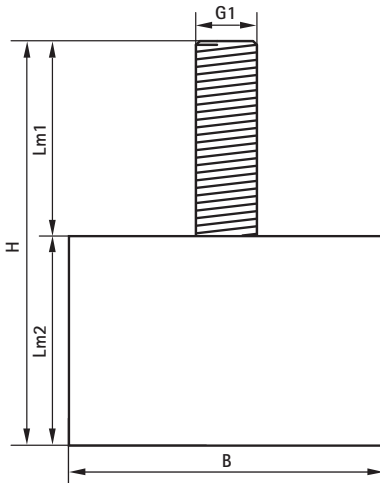

Specifications and Packaging

Part No.	Dimension	Max. Deflection (mm)	Max. load (N)	G	H	h	Lm1	B
2801700180	180/M6	2.0	180	M6	38	20	18	20
2801700290	290/M6	2.0	290	M6	38	20	18	25
2801700420	420/M8	2.5	420	M8	48	25	23	30
2801700750	750/M8	4.0	750	M8	63	40	23	40
2801701170	1170/M10	4.0	1170	M10	68	40	27	50
2801701690	1690/M12	4.0	1690	M12	77	40	37	60

See Product Data Sheet for further technical information.

PR-T Rubber Tile Pad

A versatile rubber tile pad for general vibroacoustic isolation applications

Features and Benefits



- Ideal for use as an elastic isolating support for equipment and metal structures
- Supplied as a mat of 64 blocks (8x8) joined by a membrane
- Individual 50x50mm pieces can be easily cut to form required support shape
- Transforms to elastic base support when used with a hexagon head screw
- Reusable in the event of machine relocation
- Simple to cut and install

Load-displacement charts

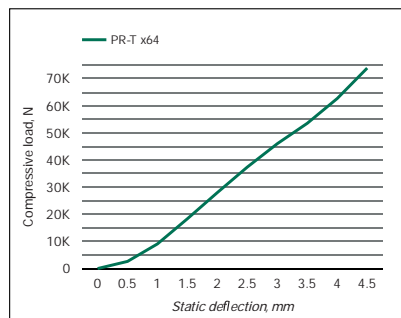
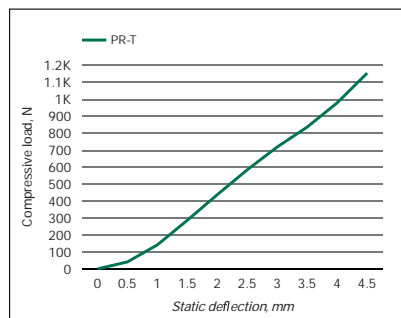
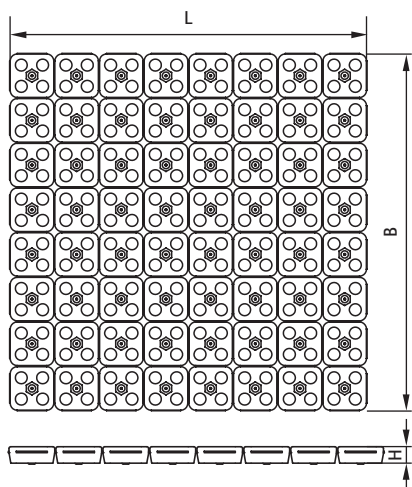

Specifications and Packaging

Part No.	Dimension	Max. Deflection (mm)	Min. load (N)	Max. load (N)	Min. optimal load (N)	Max. optimal load (N)	L	B	H
2801200400	400x400mm	4.5mm	2500	74000	9000	52000	411.2	411.2	18
-	50x50mm	4.5mm	39	1156	140	812	50	50	18

See Product Data Sheet for further technical information.

Walraven VibraTek®

SA-W Silent Washer

Silent rubber washer for isolating metal to metal contact

Features and Benefits



- Viscoelastic rubber washers that cushion and prevent transmission of vibroacoustic effects to the structure

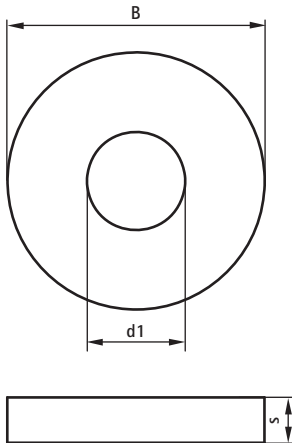

Specifications and Packaging

Part No.	Dimension	s	d1	B
2801306503	6.5x3mm	3	6.5	17
2801308504	8.5x4mm	4	8.5	25
2801308508	8.5x8mm	8	8.5	25
2801310505	10.5x5mm	5	10.5	25
2801312506	12.5x5mm	5	12.5	30
2801316515	16.5x15mm	15	16.5	50

See Product Data Sheet for further technical information.

Selection matrix



MS-M Spring Mount MS-1 Spring Mount MS-1X Spring Mount MS-1X-CBL Spring Mount MS-2X Spring Mount MS-4 Spring Mount

Walraven VibraTek®		MS-M Spring Mount	MS-1 Spring Mount	MS-1X Spring Mount	MS-1X-CBL Spring Mount	MS-2X Spring Mount	MS-4 Spring Mount
Page number		12	13	14	15	17	18
Nominal deflection	(mm)	12	23	25	25	25	23
Nominal load	(N)	150 - 1000	50 - 1000	1000 - 6000	1000 - 6000	3000 - 12000	1000 - 5000
Application range	Compressors	+	++	+++	+++	+++	++
	Pumps	++	++	+++	+++	+++	++
	Refrigeration plants		++	+++	+++	+++	++
	Air conditioners		++	+++	+++	+++	++
	Industrial air conditioning		++	+++	+++	+++	++
	Cooling plants		++	+++	+++	+++	++
	Air conditioners and splits	++	+++				
	Transformers				+++	+++	++
	Industrial dehumidifiers	++	++	++	++	++	++
	Fan coils suspended						
	Boilers						
	Pools pressure groups	+++	+++	+++			
	Fire fighting groups						
	Electromechanical elevators					+++	++
	Suspension of steel pipe and valves in the industry						
	Suspension machinery and pipes						
Ventilation ducts							
Metal structures							

V (%) Result: 93.9 - 98.9 = Perfect (+++); 87.5 - 93.9 = Very good (++); 81.1 - 87.5 = Good (+)



MR-B Rubber Mount	MR-L Levelling Mount	MR-L Levelling Mount	MR-L Levelling Mount	MR-L Levelling Mount	HS-1 Spring Hanger	HS-1X Spring Hanger	HR-1 Rubber Hanger	SA-3 Silent Absorber	SB-MM Silentblock	PR-T Rubber Tile Pad
19	20	21	22	23	24	25	26	29	30	34
3.5 - 5.5	4	7.5	4	7.5	23	25	7	7	2 - 4	4.5
240 - 1500	1000	3000	5000	8000	50 - 1000	1000 - 6000	300 - 450	300 - 450	180 - 1690	1156
+	+	+	+	+						+
+	+	+	+	+						+
+	+	+	+	+						+
+	+	+	+	+						+
+	+	+	+	+						+
+	+	+	+	+				++	++	
+	+	+	+	+						+
+	+	+	+	+						+
					+++	+++	++	++	++	
	++	++	++	++						++
	+	+	+	+						+
	+	+	+	+						+
	+	+	+	+						+
	+	++	++	++	+++	+++	++	+		
					+++	+++	++	+		
					+++	+++	++	+		
	++	++	++	++						+++

The suitability of the product indicated in the table above is determined by the combination of the typical disturbing frequency and the weight of the device, and the elasticity module of the isolator.



Walraven VibraTek®

*Vibration isolators for
equipment and systems
in buildings*

Technical Support and Advice

Our Technical Support Team is ready to guide you through the selection process of the correct isolator. We will ask you the right questions to determine the circumstances of the application, perform relevant calculations and recommend the most effective Walraven VibraTek® solution.

To find out how we can support you, visit walraven.com/en/vibration-isolation.

Find out how we can support you

Would you like to find out more about any of the solutions described in this brochure?

Or would you like to discuss how we could help you find the best possible solution for your project? Get in touch today!